

# Actuator

## MK67

MK67 is an economical actuator for medical applications with the advantages of short installation dimension and small size of the motor box. It can be equipped with dual Hall sensors to feedback positioning signals. Mainly used in applications such as home care and medical beds.

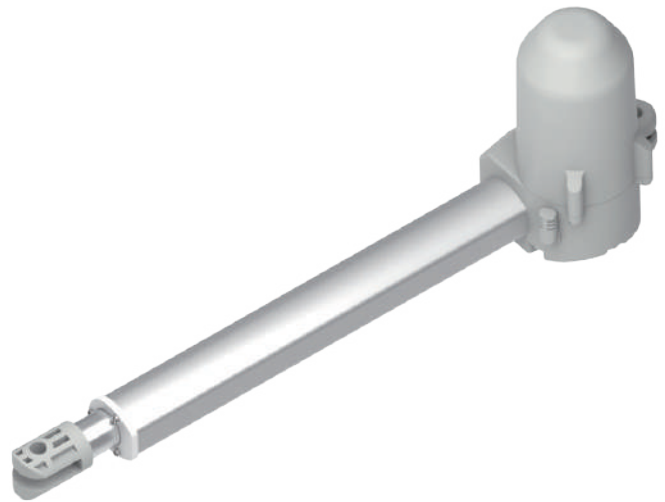

### Features and Options

---

**Main applications:** Medical, Home care

**Standard features:**

- Input voltage: 24V DC
- Max. load: 6000N (push) / 3000N (pull)
- Typical speed at full load: 2.7mm/sec (6000N load)
- Stroke: 50 ~ 300mm
- Noise level:  $\leq 50$ dB
- IP level: IPX5
- Aluminum alloy outer tube
- Color: Light gray RAL 7035
- Duty cycle: 10%, max. 2 min. continuous operation in 20 min.
- Ambient operation temperature: +5°C ~ +40°C

**Options:**

- Positioning signal feedback with dual Hall effect sensors
- Push only
- Pivot orientation of rear connector 90°

## Performance Data

Model No.	Push Max. (N)	Pull Max. (N)	*Braking ability (N)	**Typical Speed (mm/s)		**Typical Current (A)	
				No load	Full load	No load	Full load
MK67-24-A4...	6000	3000	6000	3.8	2.7	0.8	2.8
MK67-24-A8...	3000	2000	3000	7.8	5.2	0.5	3.0

Speed vs. Load

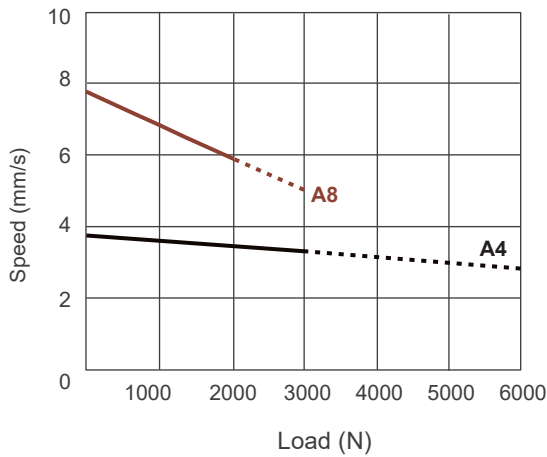

Current vs. Load

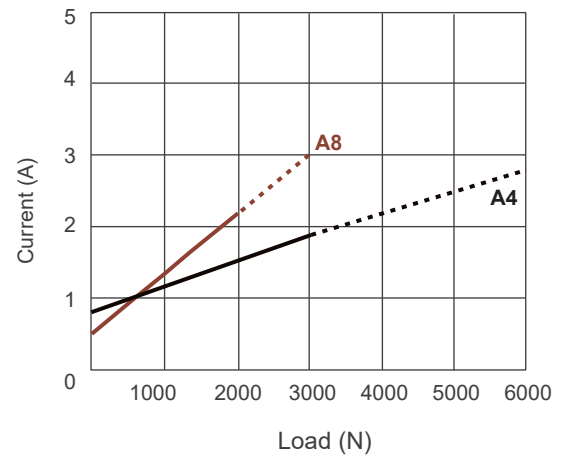

Push / Pull Load — Push Load - - -

### Remarks:

\* Equipped with mechanical brakes for thrust applications only.

\*\* The typical speed and current are the average value neither upper limit nor lower limit, which measured under room temperature and stable power. The performance curves are made with typical values.

## Dimensions

- Retracted length (A):

Unit: mm

Front connector	Retracted length(A)
1	$A \geq S + 170\text{mm}$
3, 7	$A \geq S + 142\text{mm}$

- Available stroke (S) range = 50 ~ 300 mm
- Extended length (B) = Retracted length (A) + Stroke (S)

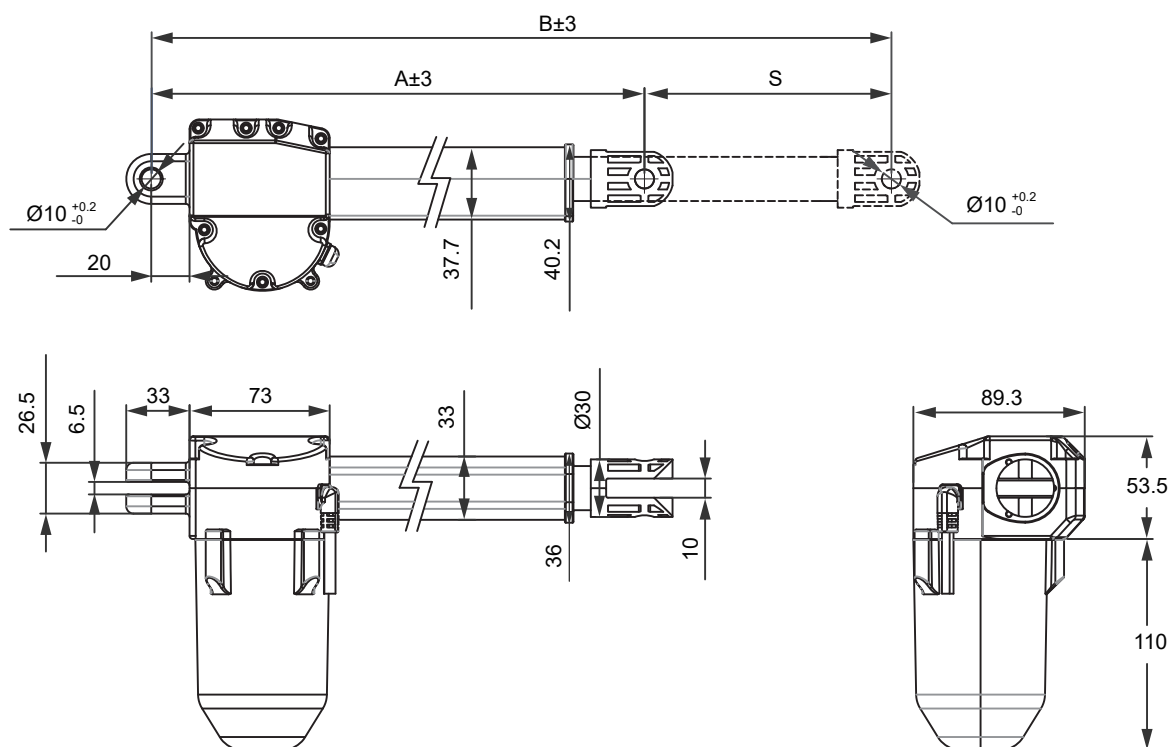

● Front connector

1: Plastic

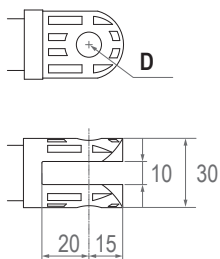

3: Drilled hole with bushing

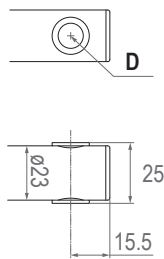

7: Plastic bushing

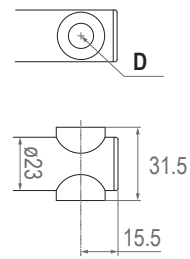

● Rear connector

1: Plastic

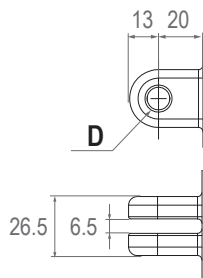

Front connector code	Diameter of pivot (D)
1	Ø8, Ø10, Ø12
3	Ø8, Ø10
7	Ø10
Rear connector code	Diameter of pivot (D)
1	Ø10

● Pivot orientation of rear connectors

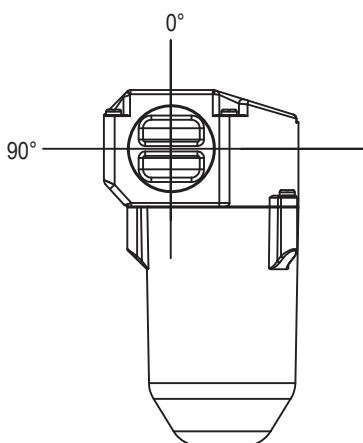

\*Remarks: As an example in 0° orientation for rear connector.

## Compatibility

Product	Model	MK67 spec
<b>Control box</b>	CB4P	- Without positioning sensor feedback - With Moteck H-type 4-pin DIN plug
	CB5P-M, CM41-M	- With dual Hall effect sensors - With Moteck LR-type minifit 6-pin plug
	CM45, MD6C-M	- Without positioning sensor - With Moteck V-type or H-type 4-pin DIN plug
	MD6C-M	- With dual Hall effect sensors - With Moteck V-type or H-type 6-pin DIN plug

## Cable Plug

• **With Moteck H-type, V-type or LR-type plug:**

- Without Hall effect sensor

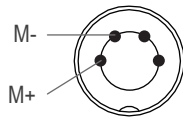

H-type or V-type 4-pin DIN plug

- With dual Hall effect sensors

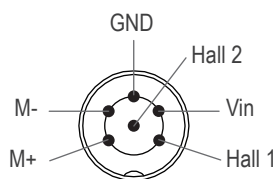

H-type or V-type 6-pin DIN plug

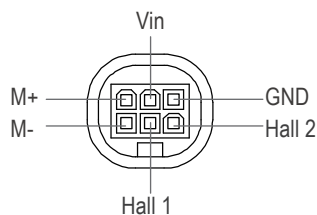

LR-type minifit 6-pin plug



H-type



V-type



LR-type

## Cable with Flying Leads

### Without positioning feedback

	Wire color	Definition	Comments
Power wires	Red	DC power	Connect red wire to "Vdc +" & black wire to "Vdc -" of DC power to extend the actuator. Switch the polarity of DC input to retract it.
	Black		

### With dual Hall effect sensors for positioning

	Wire color	Definition	Comments						
Power wires	Blue	DC power	Connect blue wire to "Vdc +" & Brown wire to "Vdc -" of DC power to extend the actuator. Switch the polarity of DC input to retract it.						
	Brown								
Signal wires	Yellow	Vin	Voltage input range: 5 ~ 20V						
	Red	Hall 1 output	High= Input - 1.2V ( $\pm 0.6V$ ) Low= GND Hall signal data:  <p style="text-align: center;">Actuator extends                      Actuator retracts</p>						
	Green	Hall 2 output	Hall effect sensor resolution: <table border="1" style="width: 100%; text-align: center;"> <thead> <tr> <th>Model No.</th> <th>Resolution (pulses/mm)</th> </tr> </thead> <tbody> <tr> <td>MK67-24-A4-XXX.XXX-XXXXXXXX</td> <td>10.0</td> </tr> <tr> <td>MK67-24-A8-XXX.XXX-XXXXXXXX</td> <td>2.5</td> </tr> </tbody> </table>	Model No.	Resolution (pulses/mm)	MK67-24-A4-XXX.XXX-XXXXXXXX	10.0	MK67-24-A8-XXX.XXX-XXXXXXXX	2.5
	Model No.	Resolution (pulses/mm)							
MK67-24-A4-XXX.XXX-XXXXXXXX	10.0								
MK67-24-A8-XXX.XXX-XXXXXXXX	2.5								
Black	GND								

## Ordering Key

	<b>MK67 - 24 - A4 - 220 - 270 - 1 1 0 H P 5 0</b>
<b>Input voltage</b>	<b>24:</b> 24V DC
<b>Motor and Spindle type</b>	<b>A4:</b> 2500rpm / 4mm pitch <b>A8:</b> 2500rpm / 8mm pitch
<b>Retracted length</b>	<b>XXX</b> (Refer to Page 3)
<b>Extended length</b>	<b>XXX</b> (Refer to Page 3)
<b>Front connector</b>	<b>1:</b> Plastic <b>3:</b> Drilled hole with bushing <b>7:</b> Plastic bushing
<b>Rear connector</b>	<b>1:</b> Plastic
<b>Pivot orientation of rear connector</b>	<b>0:</b> 0° (standard) <b>9:</b> 90°
<b>Positioning feedback</b>	<b>0:</b> None <b>H:</b> dual Hall effect sensors
<b>Option</b>	<b>0:</b> None <b>P:</b> Push only (PO)
<b>IP Level</b>	<b>5:</b> IPX5
<b>Cable length</b>	<b>0:</b> 300mm straight <b>3:</b> 1000mm straight <b>6:</b> 2000mm straight <b>A:</b> 450mm with 300mm coiled

**Terms of Use**

The user is responsible for application suitability of Moteck products. As ongoing improvement process continues, products listed on the Moteck website are subject to change without prior notice. Moteck reserves the right to terminate the sales or remove any product displayed on the website, or listed in its catalogues.